

Website 网站



WeChat 微信

ENGEL MACHINERY (CHANGZHOU) CO., LTD.
No. 9 Longfan Road, Wujin National Hi-Tech Industrial Zone,
Changzhou 213166, Jiangsu Province, P.R. China
tel: +86 519 8159 5300
fax: +86 519 8159 5388
e-mail: info@wintec-machines.com

恩格尔注塑机械（常州）有限公司
中国江苏省常州市武进国家高新技术开发区龙帆路9号
邮编：213166
电话：+86 519 8159 5300
传真：+86 519 8159 5388
邮箱：info@wintec-machines.com

www.wintec-machines.com

WINTEC
MEMBER OF THE ENGEL GROUP



WINTEC, MEMBER OF THE ENGEL GROUP, offers injection molding machines for single - shot applications. The streamlined portfolio is targeted to best meet the requirements of standard plastics production. Designed and engineered in Europe, the WINTEC product lines offer great benefits of decades of expertise in injection molding: most reliable and efficient machines with an extended service life. As a 100% ENGEL owned brand, WINTEC is committed to the high quality standards of the group. Leading after sales support is guaranteed by the local service network and an in-house spare parts supply.

赢泰——恩格尔集团成员，提供适用于单色应用的注塑机。其优质的产品旨在最好地满足标准塑料生产的需求。在欧洲设计研发，赢泰的产品线得益于注塑行业几十年的经验：有着绝佳的可靠性、高效性及超长的机器寿命。作为恩格尔集团的全资子公司，赢泰忠于集团的高质量标准。广泛的服务网络、及时迅速的备件响应，确保了领先的售后支持。

WINTEC

COMMITTED TO QUALITY AND AVAILABILITY

A STRONG PARTNER NEARBY

赢泰

质量至上，可靠为先

强大的合作伙伴

WINTEC is based in Changzhou (Jiangsu Province) in China.

The local dedicated and experienced WINTEC sales team is your partner – in Asia, Middle East, Americas, Africa, Russia, and is expanding continually. We offer standard, still customized solutions to enhance your competitiveness, meanwhile focusing on what matters to you – state-of-the-art efficiency and reliability.

赢泰工厂位于中国江苏省常州市。

当地经验丰富的销售团队也是您的合作伙伴，如今赢泰销售网络已遍布亚洲、中东、美洲、非洲、俄罗斯等，并在不断拓展。为提升您的企业竞争力，我们提供标准但仍可定制的解决方案，同时，专注于您所关心的——卓越的能效及可靠性。



ENGEL GROUP

9 PRODUCTION PLANTS

30 SUBSIDIARIES

60 REPRESENTATIVES

恩格尔集团

9个生产工厂

30个分支机构

60个代表处

e-win

YOUR ADVANTAGES AT A GLANCE

优势一览

ALL-ELECTRIC

全电动

All of the e-win's movements are servo-electrically driven. The all-electric drives allow best-in-class efficiency and maximum precision of all movements. The resulting process stability guarantees high output of quality parts.

所有e-win 的运转都由伺服电动马达来完成。全电动助力机器实现一流的效能和最大化的运转精度。做人的稳定性确保了合格部件的高产出。

SAVING COSTS

节约成本

Thanks to the all-electric drive technology, the e-win is extremely energy efficient. This saves money – shot by shot and reduces your part costs. 得益于全电动驱动技术，e-win 成为节能冠军。通过一模接一模的生产，e-win 您节省很多开支，将部件成本降低到惊人的程度。

SAVING SPACE

节省空间

Thanks to its extremely compact design the machines make optimum use of your floor space, giving you more value for your money. This means: place more machines and add capacity – benefit from additional productivity.

e-win助您节省空间，极其紧凑的设计使您的空间利用率最大化，带给您超值的体验。这意味着：单位面积会产生更高的生产率。换句话说，机器越多，单位产能就越大。

FLEXIBLE AND MODULAR

灵活且模块化

The e-win is equipped with the proven and user-friendly WINTEC C2 control unit, that offers you a high degree of flexibility on all WINTEC machines. It is fast and highly efficient, allowing you to run even complex injection molding applications.

e-win 使用经过验证且界面友好的WINTEC C2 控制单元，它给所有WINTEC机器提供了极大的灵活性。e-win 快速且高效，让您可执行更复杂的注塑应用。

FAST, FASTER

快速，更快捷

The e-win sets a new standard with up to 22 m/s² acceleration on the injection axis. This, and other impressive machine parameters guarantee short cycle times and maximum productivity for your production.

e-win 创造了注射轴最大加速度22m/s²的新标准。再结合许多其它可观的参数，它确保了生产中短暂的循环时间和最大化的产能。



e-win Clamping Unit 锁模单元

			500	1000	1800	2800
Clamping force	锁模力	kN	500	1000	1800	2800
Opening force	开模力	kN	50	100	180	280
Opening stroke max	最大开模行程	mm	260	350	460	600
Mold height min	最小模厚	mm	150	150	250	250
Mold height max	最大模厚	mm	350	450	600	600
Platen size hor. X vert.	模板尺寸	mm	520x470	650x600	760x760	1070x1070
Distance between tie bar hor. X vert.	四柱间距	mm	370x320	460x410	520x520	730x730
Ejector stroke	顶针行程	mm	100	100	150	200
Ejector force forward /return	顶针力	kN	22/ 22	22/ 22	37/ 37	77/ 77
Mold weight, max on moving platen /center of gravity	动板最大模具重量 / 重心距离	kg/mm	320/117	650/150	1250/185	2400/200
Number of mold cooling circuits	模具冷却水	nxl/min	4x10	4x10	6x10	6x10
Dry operation time	干周期	sec/mm	1.0/250	1.4/320	1.7/320	2.1/420

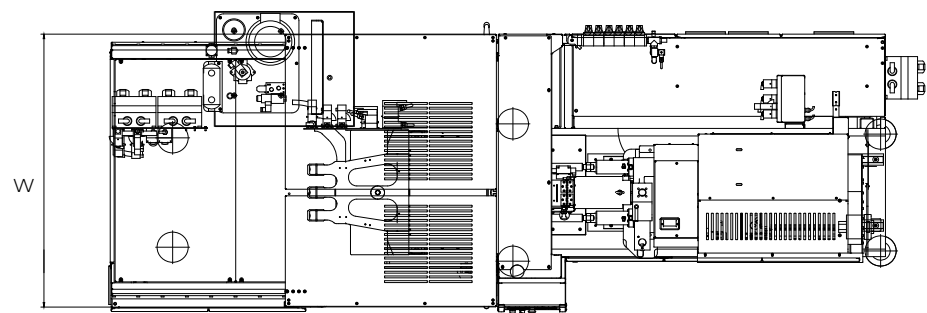
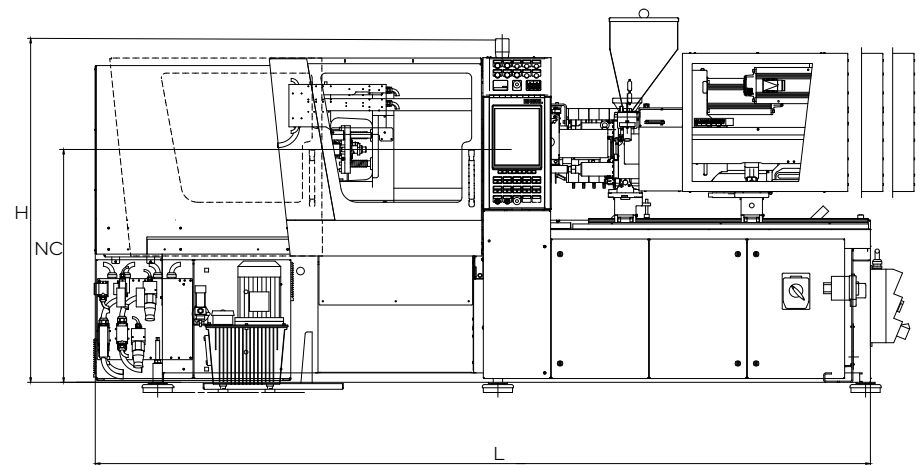

e-win Machine Dimensions 机器尺寸

			e-win 500		e-win 1000			e-win 1800				e-win 2800			
			50	170	170	310	440	310	440	740	940	440	740	940	1340
Length (L)	长	mm	3660	3985	4485	5405	5800					6242			
With (W)	宽	mm	1440	1472			1585				2000				
Height (H)	高	mm	1720	1820			2100				2100				
Height nozzle center (NC)	喷嘴中心高度	mm	1185	1235			1340				1475				

e-win Platen Dimensions 模板尺寸

500 kN

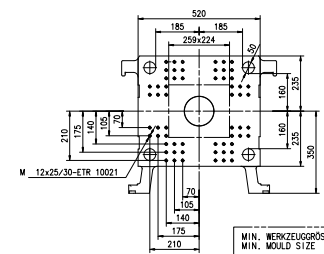
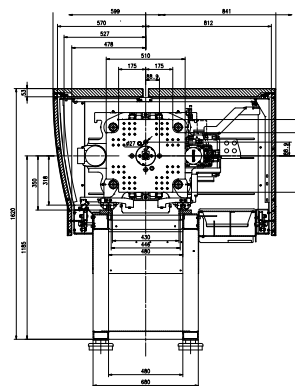

1000 kN

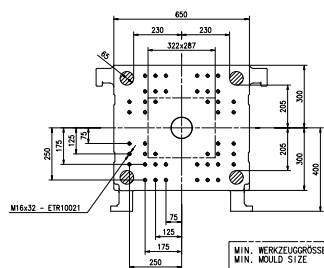
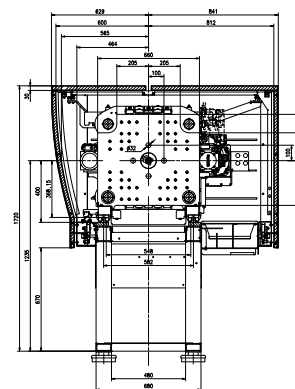

1800 kN

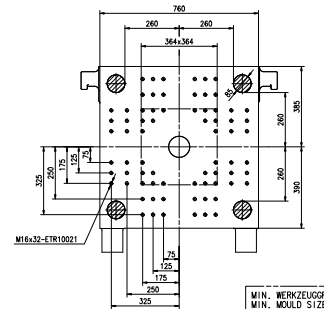
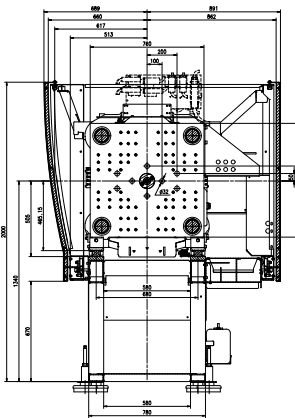

2800 kN

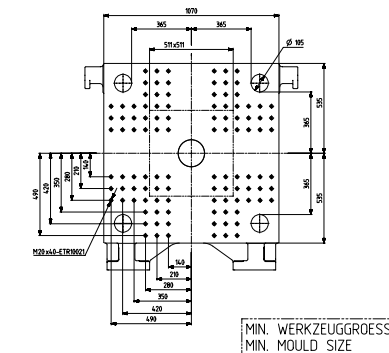
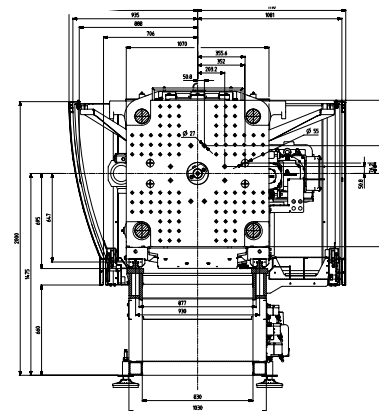

e-win			e-win 500		e-win 1000			e-win 1800				e-win 2800			
			50	170	170	310	440	310	440	740	940	440	740	940	1340
Machine weight	机器净重	t	3.1	3.2	4.4	4.8	4.8	7.5	7.5	8.2	8.2	15.6	16.5	16.5	18
Drive power standard/high/premium	驱动功率标准 / 高速 / 超高速	kw	- 6.1 8.8	- 9.7 12.5	- 9.2 11.0	- 13.7 17.9	- 17 28	- 14.5 18.7	- 17.3 29.1	19.1 26.3 -	26.8 34 -	- 20.3 30.5	21.7 31.8 -	28.6 39.4 -	54.5 65.9 -
Heating capacity injection unit max.capacity max.zones	加热功率功率 / 组	kw/n	5.1 4	7.0 4	7.0 4	9.2 4	9.2 4	9.2 4	9.2 4	15.3 5	16.3 5	9.2 4	15.3 5	16.3 5	21.3 5
Total power standard/high/premium	总功率标准 / 高速 / 超高速	kw	- 10.7 13.3	- 15 18	- 14.9 16.8	- 21.0 25.3	- 24.4 35.5	- 21.9 26.2	- 24.8 36.6	30.9 38.1 -	39.2 46.5 -	- 30 41	36 46 -	44 54 -	73 84 -
Connected current standard/high/premium ¹	接入电流标准 / 高速 / 超高速 ¹	A	- 16.5 20.3	- 22 26	- 22.5 25.2	- 31.4 37.5	- 36.2 52.2	- 32.7 38.8	- 36.8 53.8	50.9 61.4 -	58.9 69.4 -	- 43 59	52 67 -	63 79 -	105 122 -

1. With voltage 电源 3×380V-400V+N+PE, 50/60HZ

e-win Injection Unit 注射单元																																								
			iu 50						iu 170						iu 310				iu 440				iu 740						iu 940						iu 1340					
			high 高速			premium 超高速			high 高速			premium 超高速			high 高速		premium 超高速		high 高速		premium 超高速		standard 标准		high 高速				standard 标准		high 高速				standard 标准		high 高速			
Screw diameter	螺杆直径	mm	15	18	20	15	18	20	22	25	30	22	25	30	30	35	30	35	35	40	35	40	45	50	55	45	50	55	50	55	60	50	55	60	55	60	70	55	60	70
Screw stroke	射胶行程	mm	80						120						160				175				200						220						260					
Max. injection capacity	注射容积	cm ³	14.1	20.4	25.1	14.1	20.4	25.1	46	59	85	46	59	85	113	154	113	154	168	220	168	220	318	392	475	318	392	475	432	522	622	432	522	622	617	735	1000	617	735	1000
Screw speed max	螺杆转速	min ⁻¹	450						400						420				420				300						267						250					
L/D ratio (3-zone screw)	螺杆长径比 (三段式螺杆)	L/D	24						24	24.8	20.5	24	24.8	20.5	23.6	20	23.6	20	20				20						20						20					
Recovery rate (3-zone screw) ¹	熔胶率 (三段式螺杆) ¹	g/s	2.8	4.2	6	2.8	4.2	6	6.4	10	14.2	6.4	10	14.2	14.7	22.1	14.7	22.1	22.1	33.6	22.1	33.6	31	42	56	31	42	56	37	50	62	37	50	62	44.9	55.6	81.6	44.9	55.6	81.6
Injection rate	射胶速率	cm ³ /s	88	127	157	141	204	220	126	163	235	126	163	235	235	320	442	600	255	333	480	630	280	346	418	280	346	418	295	356	424	295	356	424	511	608	827	511	608	827
Injection pressure	射胶压力	bar	2400	2400	2000	2400	2400	2000	2400	2400	2000	2400	2400	2000	2400	2000	2400	2000	2400	2000	2400	2000	2400	2000	1650	2400	2000	1650	2200	1810	1520	2200	1810	1520	2300	1930	1420	2300	1930	1420
Hold pressure max ³	保压压力 ³	bar	2160	2160	1800	2160	2160	1800	2160	2160	1800	2160	2160	1800	2160	1800	2160	1800	2160	1800	2160	1800	2160	1800	1480	2160	1800	1480	1980	1620	1360	1980	1620	1360	2070	1730	1270	2070	1730	1270
Nozzle stroke	喷嘴行程	mm	200						225						225				305				400						400						400					
Nozzle penetration	喷嘴伸出模面距离	mm	30						30						30				30				30						30						30					
Nozzle contact force	喷嘴接触力	kN	20						28						28				28				50						50						50					
Heating wattage	加热功率	kW	4.3	5.1	5.8	4.3	5.1	5.8	6.08	6.95	6.95	6.08	6.95	6.95	9.2	9.2	9.2	9.2	9.2	9.2	9.2	9.2	13.3	15.3	16.3	13.3	15.3	16.3	15.3	16.3	18.3	15.3	16.3	18.3	19.8	21.3	24.3	19.8	21.3	24.3
Heating zones incl. Nozzle	加热区 (含喷嘴)		4						4						4				4				5						5						5					

1. Values for polystyrene

聚苯乙烯的值

2. Injection pressure limited

注射压力限定

3. The height of the holding pressure is dependent on the holding pressure duration as well as on the total cycle

保压压力峰值取决于保压时间及周期时间